

Electric Pallet Truck

With capacity of 1,500 to 2,000kg



- / The truck is simple and dexterous, with small turning radius and small weight. It is suitable for ultra-narrow channel operation.
- / The truck has compact and reliable structure. The oil pipeline and line are wrapped in the truck body which is safe and beautiful and convenient for user maintenance.
- / The truck adopts integrated handle design integrating key switch and electric meter which is simple and comfortable for operation.
- / Hand-held lithium battery makes battery changing easier and more convenient.
- / Standard configuration of emergency stop switch and emergency reverse device ensure truck safety.
- / The truck is assembled with power-off braking function. The truck is braked as soon as the handle is loosened or pressed to the bottom.
- / Electromagnetic braking and motor braking are used to ensure the safety of driving.



Option: Lowering with electric power

Standard: Manual lowering

Electric Pallet Truck Specification

Characteristics	1.1	Manufacturer	HANGCHA GROUP CO.,LTD.			
		1.2	Model	CBD15-JL3	CBD18-JL3	CBD20-JL3
	1.3	Power unit	Electric	Electric	Electric	
	1.4	Operation	Pedestrian	Pedestrian	Pedestrian	
	1.5	Rated traction weight	Q (t)	1.5	1.8	2.0
	1.6	Load centre	c (mm)	600	600	600
	1.8	Axle centre to fork face	x (mm)	944	944	944
	1.9	Wheel base	y (mm)	1243	1243	1243
Weights	2.1	Service weight with battery	kg	142	142	146
Wheels, Tyres	3.1	Wheels type		PU	PU	PU
	3.2	Driving wheel size	Φ×w(mm)	Φ210×70	Φ210×70	Φ210×70
	3.3	Bearing wheel size	Φ×w(mm)	Φ80×60	Φ80×60	Φ80×60
	3.5	Wheels, number front/rear (x = driven)		1x/4	1x/4	1x/4
	3.7	Track width	b11 (mm)	400/535	400/535	400/535
Dimensions	4.4	Lift	h3 (mm)	200	200	200
	4.9	Overall height(With handle)	h14 (mm)	740/1160	740/1160	740/1160
	4.15	lowered height	h13 (mm)	85	85	85
	4.19	Overall length	l1 (mm)	1603	1603	1603
	4.20	Length to fork face	l2 (mm)	453	453	453
	4.21	Overall width	b1/ b2 (mm)	550/685	550/685	550/685
	4.22	Fork dimensions	s/e/l (mm)	50/150/1150	50/150/1150	50/150/1150
	4.25	Width of forks	bs (mm)	550/685	550/685	550/685
	4.32	Min.Ground clearance	m2 (mm)	35	35	35
	4.33	Aisle width with pallet 1000 x 1200 across forks	Ast (mm)	1804	1804	1804
4.34	Aisle width with pallet 800 x 1200 along forks	Ast (mm)	1854	1854	1854	
4.35	Min.Turning radius	Wa (mm)	1398	1398	1398	
Performance	5.1	Travel speed,laden/unladen	(km/h)	4.2/4.5	4.2/4.5	4.2/4.5
	5.8	Maximum climbing ability, with/without load	(%)	5/10	5/10	5/10
	5.10	Service brake		Electromagnetic	Electromagnetic	Electromagnetic
Drive	6.1	Drive motor, 60 minute rating	(kW)	0.75	0.75	0.75
	6.2	Lift motor rating at S3 15%	(kW)	0.8	0.8	0.8
	6.3	Battery according to DIN 43531/35/36 A,B,C,no		no	no	no
	6.4	Battery voltage/rated capacity	(V/Ah)	24/20	24/20	48/20
	6.5	Battery weight (± 5%)	(kg)	6	6	10.2
Others	8.1	Type of drive control		DC	DC	DC
	8.4	Noise level at operator's ear	(dB(A))	≤70	≤70	≤70
	10.5	Steering type		Mechanical steering	Mechanical steering	Mechanical steering

Option:
 Auxiliary wheels
 Rema handle with Pin Code
 Lithium battery 24V/30Ah, 24V/40Ah, 24V/60Ah (for 1.5-1.8t)
 Lithium battery 48V/30Ah (for 2.0t)

The World of Hangcha



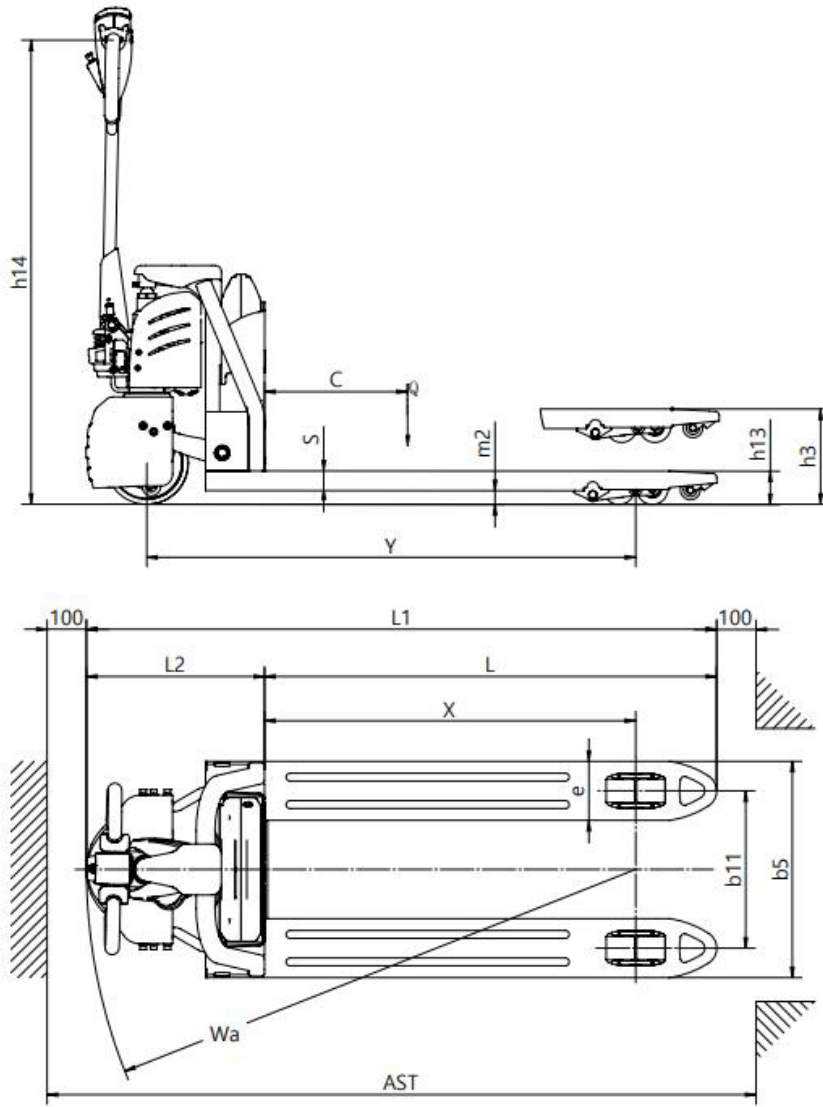

ZHEJIANG HANGCHA IMP. & EXP. CO., LTD.

Factory site: 666 Xiangfu Road,
Hangzhou, Zhejiang, China (311305)

Tel: +86-571-88926735 88926755
Fax: +86-571-88926789 88132890

sales@hcforklift.com
www.hcforklift.com



Follow us on
Facebook



Follow us on
YouTube



Follow us on
WeChat



Download "Hangcha
Forklift" App



ISO14001
ISO14001:2015



ISO9001
ISO9001:2015



HANGCHA trucks conform
to the European Safety
Requirements.