



ZHEJIANG HANGCHA IMP. & EXP. CO., LTD.

Factory site: 666 Xiangfu Road,
Hangzhou, Zhejiang, China (311305)

Tel: +86-571-88926735 88926755
Fax: +86-571-88926789 88132890

sales@hcforklift.com
www.hcforklift.com



Follow us on
Facebook



Follow us on
YouTube



Follow us on
WeChat



Download "Hangcha
Forklift" App



ISO14001
ISO14001:2015



ISO9001
ISO9001:2015



HANGCHA trucks conform
to the European Safety
Requirements.

2022 VERSION 1.1 COPYRIGHT 2022/01

HANGCHA GROUP CO., LTD. reserves the right to make any changes without notice concerning colors, equipment, or specifications detailed in this brochure, or to discontinue individual models. The colors of trucks, delivered may differ slightly from those in brochures.



X Series 3-Wheel Electric Forklift Truck With Lithium Iron-Phosphate

with capacities of 1,300 to 1,500kg

The World of Hangcha
SINCE 1956



X Series 3-Wheel Electric Forklift Truck With Lithium Iron-Phosphate

Hangcha's X series 1.3-1.5t three-point electric forklifts are a new series of high-efficiency, energy-saving electric counterweight forklifts with a new structure that represents a breakthrough over the traditional design concept. With a compact structure, small turning radius and light weight and high maneuverability, the vehicle is widely used in narrow operation places, e.g., warehouses, supermarkets, workshops, etc.



Appearance

/ With a profile formed by a combination of straight lines and streamlined curved surfaces, the vehicle is compact and maneuverable and has simple and sturdy appearance.

Comfort

/ The angle of the hand wheel is adjustable and the seat can be adjusted backwards and forwards, so that the operator can choose the best driving position.
/ Excellent ergonomic design and large operation space provide the operator with more comfort, and satisfy the operator's needs for long-term and high-intensity operations.

Safety

/ The optimized design of the wide-view mast and the low dashboard enable a wide front view and higher safety, and minimizes the blind view to the greatest extent.
/ The emergency shut-off switch equipped for the standard configuration complies with European safety standards.
/ The electronic and hydraulic overload protection devices comply with safety regulations.
/ An optional seat sensing system is provided to enable high safety by disabling the traction, lifting, descending and other functions when the driver leaves the seat.

Energy saving and high efficiency

/ Front-wheel drive; standard rubber tread tires, which are not prone to skid on slippery grounds such as puddles, sandy, sloping or cold storage grounds, etc.
/ Efficient and convenient vehicle-mounted charger provided for the standard configuration.
/ The vehicle is equipped with energy-saving and durable LED lights.

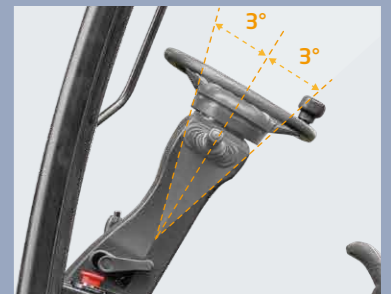

The angle of the hand wheel is adjustable



Seat can be adjusted backwards and forwards



Low dashboard



Vehicle-mounted charger



Standard rubber tread tires



Wide-view mast

Advancement

- / AC devices, precise speed control, maintenance-free motor, temperature monitoring.
- / The forklift is equipped with an AC controller to enable its driving, steering, lifting, tilting and other actions to be controlled by a computer.
- / The high-efficiency driving control system with a high-frequency integrated MOSFET controller ensures stable and accurate driving and lifting and superior speed regulation performance, and has the functions of regenerative braking, reverse braking and protection for preventing sliding down a ramp, etc. to enable safer and more effective and comfortable operations.
- / The high quality LED battery meter can accurately display information in harsh environments.

Standard Specification

- / Tread solid tire
- / Anti-skid patterned step
- / Dual multiway valve
- / 3m duplex wide-field-of-view mast
- / Standard 920mm long fork
- / Adjustable steering wheel column
- / Rearview mirror
- / Emergency power off switch
- / Round color screen instrument
- / LED headlight
- / Combination LED tail light
- / Horn, reversing buzzer

Stability

- / With the battery and counterweight arranged and designed to have a low center of gravity, respectively, the vehicle has a low center of gravity and good stability.
- / With two rubber tires, the turn wheels provide support side by side for good turn stability.

Options

- / Seamless solid tire
- / 2-4.5m duplex wide-view mast
- / 2-4m free duplex mast
- / 3.5-4.5m free triplex mast
- / Widened fork carriage and load backrest
- / Triple and quadruple multiway valves
- / External side shift fork
- / Built-in side shift fork
- / Other attachments
- / Forks of other lengths
- / Cold storage vehicle
- / Left and right rear view mirrors
- / Rear LED operation light
- / Alarm light
- / Battery charger
- / OPS system

CATL Li-Ion battery pack specification			
Manufacturers type designation		CPDS13-XD2-SI	CPDS15-XD2-SI
Battery voltage, capacity	V/Ah	80/125	80/125
Battery weight	kg	120	120

Table of the battery features		
Capacity (Ah/5h)	1.3t	1.5t
125 (lithium battery)	●	●
202 (lithium battery)	○	○

Note: ● Standard battery capacity, ○ Optional battery capacity



X Series 1.3-1.5t 3-Wheel Electric Forklift Specification

Distinguishing mark	HANGCHA GROUP CO.,LTD.					
	1.1	Manufacturer				
1.2	Manufacturers type designation	CPDS13-XD4-SI	CPDS15-XD4-SI			
1.3	Drive: electric (battery or mains), diesel, petrol, fuel gas	electric	electric			
1.4	Operator type: hand, pedestrian, standing, seated, order-picker	seated	seated			
1.5	Load capacity/rated load	Q (kg)	1300	1500		
1.6	Load centre distance	c (mm)	500	500		
1.8	Load distance, centre of drive axle to fork	x (mm)	330	330		
1.9	Wheelbase	y (mm)	1170	1170		
Weight	2.1	Service Weight	kg	2430	2540	
	2.2	Axle loading, laden front/rear	kg	3290/440	3610/430	
	2.3	Axle loading, unladen front/rear	kg	1110/1320	1120/1420	
Tyres, chassis	3.1	Tyres: solid rubber, superelastic, pneumatic, polyurethane		solid	solid	
	3.2	Tyre size, front		18x7 - 8	18x7 - 8	
	3.3	Tyre size, rear		15x4.5 - 8	15x4.5 - 8	
	3.5	Wheels, number front rear (x = driven wheels)		2x/2	2x/2	
	3.6	Tread, front	b10 (mm)	860	860	
	3.7	Tread, rear	b11 (mm)	175	175	
	3.7	Tread, rear	b11 (mm)	175	175	
Dimensions	4.1	Tilt of mast/fork carriage forward/backward	$\alpha/\beta(^{\circ})$	5/8	5/8	
	4.2	Height, mast lowered	h1 (mm)	2065	2065	
	4.3	Free lift	h2 (mm)	135	135	
	4.4	Lift	h3 (mm)	3000	3000	
	4.5	Height, mast extended	h4 (mm)	3955	3955	
	4.7	Height of overhead guard STD.	h6 (mm)	1930	1930	
	4.9	Seat height/stand height	h7 (mm)	970	970	
	4.19	Overall length	l1 (mm)	2700	2750	
	4.20	Length to face of forks	l2 (mm)	1800	1830	
	4.21	Overall width	b1 (mm)	1030	1030	
	4.22	Fork dimensions	s/e/l (mm)	35/100/920	35/100/920	
	4.23	Fork carriage DIN 15 173 --- ISO 2328, class/type A,B		ISO2328 2A	ISO2328 2A	
	4.24	Fork-carriage width	b3 (mm)	900	900	
	4.25	Distance between fork-arms	b5 (mm)	200/900	200/900	
	4.31	Ground clearance, laden, below mast	m1 (mm)	95	95	
	4.32	Ground clearance, centre of wheelbase	m2 (mm)	90	90	
	4.34.1	Aisle width for pallets 1000 x 1200 crossways	Ast (mm)	3210	3240	
	4.34.2	Aisle width for pallets 800 x 1200 lengthways	Ast (mm)	3410	3440	
	4.35	Turning radius	Wa (mm)	1680	1710	
	Performance data	5.1	Travel speed, laden/unladen	km/h	12/13	12/13
		5.2	Lift speed, laden/unladen	m/s	0.250/0.370	0.240/0.370
		5.3	Lowering speed, laden/unladen	m/s	0.460/0.440	0.460/0.440
		5.7	Gradeability, laden/unladen	%	12/13	12/13
5.9		Acceleration time, laden/unladen (0-10m)	s	5.85/5.03	5.85/5.03	
5.10		Service brake		Hydraulic	Hydraulic	
5.11	Parking brake		Mechanical	Mechanical		
Electric-engine	6.1	Drive motor rating S2 60 min	kW	5 AC	5 AC	
	6.2	Lift motor rating at S3 15%	kW	8 AC	8 AC	
	6.4	Battery voltage, nominal capacity K5	V/Ah	80/125	80/125	
	6.5	Battery weight	kg	120	120	
		Battery dimensions	l/b/h(mm)	916×550×276	916×550×276	
		Min. battery weight	kg	120	120	
		Max. battery weight	kg	165	165	
8.1	Type of drive control		MOSFET/AC	MOSFET/AC		
9.1	Manufacturer		INMOTION	INMOTION		
Addition data	10.1	Operating pressure for attachments	bar	140	150	
	10.7	Sound level at the driver's ear according to EN / DIN 12 053	dB (A)	66	66	

1.3-1.5t Mast Specification

Type	Model	Lifting height mm	Lowered overall height mm	Overall height		Free lifting height		Tilt range		Capacity	
				With backrest	Without backrest	With backrest	Without backrest	Forward	Backward	Load center@500mm	
				mm	mm	mm	mm	deg	deg	1.3t	1.5t
2-stage wide view mast	XS15M200	2000	1578	2955	2566	135	135	5	8	1300	1500
	XS15M250	2500	1828	3455	3066	135	135	5	8	1300	1500
	XS15M270	2700	1928	3655	3266	135	135	5	8	1300	1500
	XS15M300	3000	2078	3955	3566	135	135	5	8	1300	1500
	XS15M330	3300	2228	4255	3866	135	135	5	8	1300	1500
	XS15M350	3500	2328	4455	4066	135	135	5	6	1300	1500
	XS15M370	3700	2478	4655	4283	135	135	5	6	1300	1500
	XS15M400	4000	2678	4955	4633	135	135	5	6	1300	1500
	XS15M430	4300	2828	5255	4933	135	135	5	6	1200	1450
3-stage full-free lifting mast	XS15M450	4500	2928	5455	5133	135	135	5	6	1100	1400
	XS15N350	3500	1790	4455	4100	845	1200	5	6	1200	1400
	XS15N370	3700	1840	4655	4266	895	1284	5	6	1200	1400
	XS15N400	4000	1940	4955	4566	995	1384	5	6	1200	1400
	XS15N430	4300	2040	5255	4866	1095	1484	5	6	1150	1300
	XS15N450	4500	2090	5455	5066	1145	1534	5	6	1100	1250

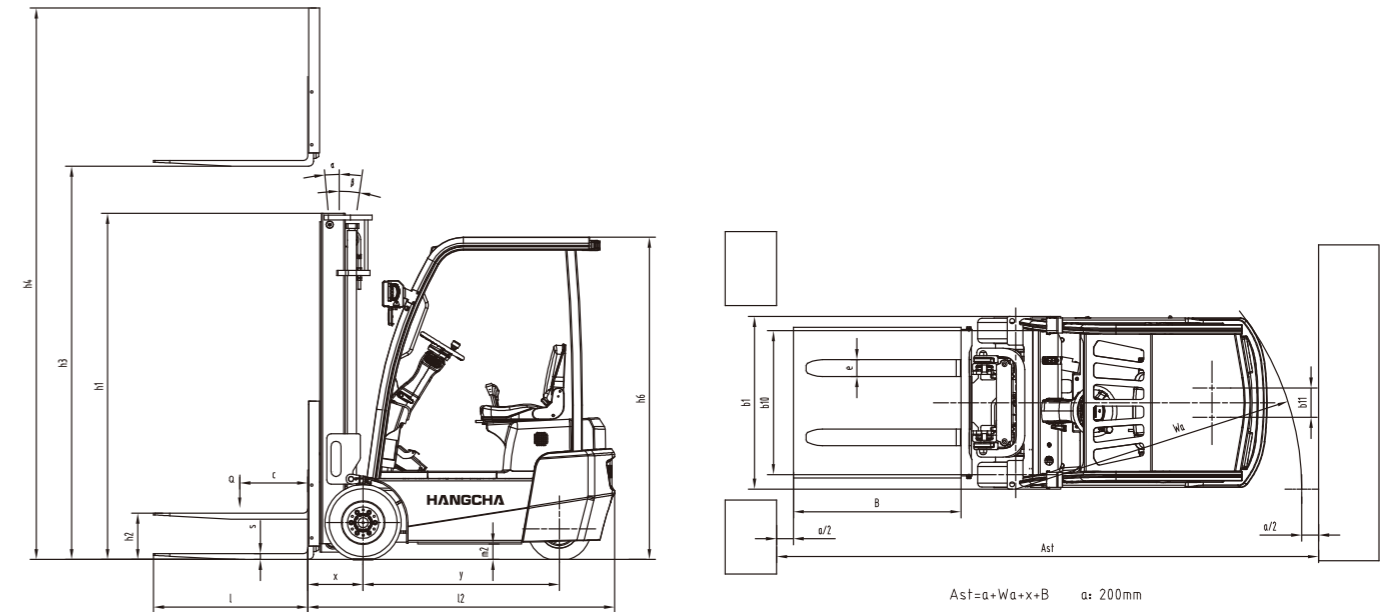

Load capacity (kg)

