

1.4/1.6t Mast Specification

Type	Lifting height h ₁	Mast lowered h ₂	Mast extended h ₃	Free lifting height h ₄	Tilting range α/β
	mm	mm	mm	mm	(°)
Wide view duplex mast	2700	1950	3665	105	2/5
	3000	2100	3965	105	2/5
	3300	2250	4265	105	2/5
	3500	2350	4465	105	2/5
	3600	2400	4565	105	2/5
	4000	2650	4965	105	2/5
	4300	2790	5265	105	2/5
	4500	2900	5465	105	2/5
	4800	3095	5765	105	2/5
	5000	3195	5965	105	2/5
Full free triple mast	4000	2030	4965	1065	2/5
	4500	2160	5465	1185	2/5
	5000	2300	5965	1335	2/5
	5500	2450	6465	1485	2/5
	6000	2625	6965	1660	2/5
	6500	2800	7465	1835	2/5
	7000	3000	7965	2035	2/5
	7500	3060	8465	2095	2/5
	8000	3250	8965	2285	2/5
	8500	3420	9465	2455	2/5
	9000	3580	9965	2615	2/5
	9500	3760	10465	2795	2/5
	10000	3920	10965	2955	2/5
	10500	4100	11465	3135	2/5
	11000	4300	11965	3335	2/5

1.8t Mast Specification

Type	Lifting height h ₁	Mast lowered h ₂	Mast extended h ₃	Free lifting height h ₄	Tilting range α/β
	mm	mm	mm	mm	(°)
Wide view duplex mast	2700	1950	3665	110	2/5
	3000	2100	3965	110	2/5
	3300	2250	4265	110	2/5
	3500	2350	4465	110	2/5
	3600	2400	4565	110	2/5
	4000	2650	4965	110	2/5
	4300	2790	5265	110	2/5
	4500	2900	5465	110	2/5
	4800	3095	5765	110	2/5
	5000	3195	5965	110	2/5
Full free triple mast	4000	2085	4965	1120	2/5
	4500	2165	5465	1200	2/5
	5000	2315	5965	1350	2/5
	5500	2490	6465	1525	2/5
	6000	2665	6965	1700	2/5
	6500	2835	7465	1870	2/5
	7000	3020	7965	2055	2/5
	7500	3180	8465	2215	2/5
	8000	3350	8965	2385	2/5
	8500	3580	9465	2615	2/5
	9000	3800	9965	2835	2/5
	9500	3970	10465	3005	2/5
	10000	4100	10965	3135	2/5
	10500	4250	11465	3285	2/5
	11000	4450	11965	3485	2/5
	11500	4700	12465	3735	2/5

2.0t Mast Specification

Type	Lifting height h ₁	Mast lowered h ₂	Mast extended h ₃	Free lifting height h ₄	Tilting range α/β
	mm	mm	mm	mm	(°)
Wide view duplex mast	2700	1950	3665	110	2/5
	3000	2100	3965	110	2/5
	3300	2250	4265	110	2/5
	3500	2350	4465	110	2/5
	3600	2400	4565	110	2/5
	4000	2650	4965	110	2/5
	4300	2790	5265	110	2/5
	4500	2900	5465	110	2/5
	4800	3095	5765	110	2/5
	5000	3195	5965	110	2/5
Full free triple mast	4000	2085	4965	1120	2/5
	4500	2165	5465	1200	2/5
	5000	2315	5965	1350	2/5
	5500	2490	6465	1525	2/5
	6000	2665	6965	1700	2/5
	6500	2835	7465	1870	2/5
	7000	3020	7965	2055	2/5
	7500	3180	8465	2215	2/5
	8000	3350	8965	2385	2/5
	8500	3580	9465	2615	2/5
	9000	3800	9965	2835	2/5
	9500	3970	10465	3005	2/5
	10000	4100	10965	3135	2/5
	10500	4250	11465	3285	2/5
	11000	4450	11965	3485	2/5
	11500	4700	12465	3735	2/5
	12000*	4900	12965	3935	2/5
	12500*	5150	13465	4185	2/5
13000*	5400	13965	4435	2/5	

* When you choose the mast, the dimensions of the truck will be affected. Please refer to the performance parameter table for details.

2.5t Mast Specification

Type	Lifting height h ₁	Mast lowered h ₂	Mast extended h ₃	Free lifting height h ₄	Tilting range α/β
	mm	mm	mm	mm	(°)
Wide view duplex mast	2700	1950	3665	110	2/5
	3000	2100	3965	110	2/5
	3300	2250	4265	110	2/5
	3500	2350	4465	110	2/5
	3600	2400	4565	110	2/5
	4000	2650	4965	110	2/5
	4300	2790	5265	110	2/5
	4500	2900	5465	110	2/5
	4800	3095	5765	110	2/5
	5000	3195	5965	110	2/5
Full free triple mast	4000	2085	4965	1120	2/5
	4500	2165	5465	1200	2/5
	5000	2315	5965	1350	2/5
	5500	2490	6465	1525	2/5
	6000	2665	6965	1700	2/5
	6500	2835	7465	1870	2/5
	7000	3020	7965	2055	2/5
	7500	3180	8465	2215	2/5
	8000	3350	8965	2385	2/5
	8500	3580	9465	2615	2/5
	9000	3800	9965	2835	2/5
	9500	3970	10465	3005	2/5
	10000	4100	10965	3135	2/5
	10500	4300	11465	3335	2/5
	11000	4500	11965	3535	2/5
	11500	4800	12465	3835	2/5
	12000*	5000	12965	4035	2/5
	12500*	5300	13465	4335	2/5
	13000*	5600	13965	4635	2/5

* When you choose the mast, the dimensions of the truck will be affected. Please refer to the performance parameter table for details.



ZHEJIANG HANGCHA IMP. & EXP. CO., LTD.

Factory site: 666 Xiangfu Road,
Hangzhou, Zhejiang, China (311305)

Tel: +86-571-88926735 88926755
Fax: +86-571-88926789 88132890

sales@hcforklift.com
www.hcforklift.com



Follow us on
Facebook



Follow us on
YouTube



Follow us on
WeChat



Download "Hangcha
Forklift" App



ISO 14001
ISO 14001:2015



ISO 9001
ISO 9001:2015



HANGCHA trucks conform to the European Safety Requirements.

2023 VERSION 4.0/COPYRIGHT 2023/07

HANGCHA GROUP CO., LTD. reserves the right to make any changes without notice concerning colors, equipment, or specifications detailed in this brochure, or to discontinue individual models. The colors of trucks, delivered may differ slightly from those in brochures.



XC SERIES REACH TRUCK WITH LITHIUM POWER

with capacity of 1,400 to 2,500kg



The World of Hangcha
SINCE 1956



A NEW DIMENSION OF PERFORMANCE

XC SERIES REACH TRUCK WITH LITHIUM POWER

- / The XC series reach truck with lithium power fully utilize the advantages of lithium battery and achieve disruptive innovations in vehicle structure, functional configuration, performance parameters, ergonomics, and operating vision.
- / We cater for a wide range of applications whilst ensuring optimum energy efficiency. Regardless of your special requirements – whether confined spaces or lifting height reaches 13m, load capacity of up to 2,500 kg or individual customisation with various options – we have the truck you need.
- / Compact size of the lithium battery pack and breaking through the traditional structure design, makes the truck style more novel and more efficient.

MAXIMUM TRAVELLING SPEED

14km/h

MAXIMUM LIFTING SPEED

0.81m/s

HIGH RESIDUAL CAPACITY

6,500mm

MAXIMUM LOAD CAPACITY

2,500kg

MAXIMUM LIFT HEIGHT

13,000mm



BEING ENVIRONMENTALLY FRIENDLY, EFFICIENT AND DURABLE

- / CATL lithium battery is standard for all series, adopting 80V voltage system which can provides fast charging and long service life and less energy loss.
- / The special-shaped lithium battery pack design provides a large operating space in the cab and a broad view.



Charging port



Battery removal

 Working time **> 10h**

 Fast charging time **≤ 2h**

Lithium battery capacity		
1.4 t	Std.	80V/250Ah
1.6 t		
1.8 t		
2.0 t	Opt.	80V/404Ah
2.5 t		

Note: Std. 80V/250Ah, Work time > 6h;
Opt. 80V/404Ah, Work time >10h



A NOVEL PROFILE STYLE AND COMPACT INTERIOR DESIGN

With fewer exposed fasteners of the inside covers, the interior is compact and stylish.

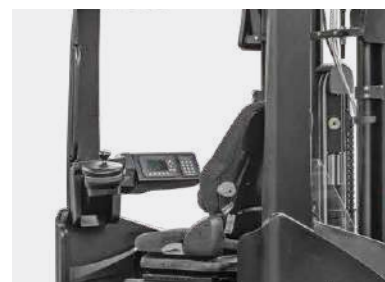

Thanks to the special-shaped design of the battery pack and the breakthrough in the body structure, which can provide a wider view.



The improved mast structure and piping arrangement enables a broader vision for stacking operations

/ The hydraulic tubing and the wires are on both sides of the mast, overlapping with the chain, making full use of the space and reducing the line of sight.

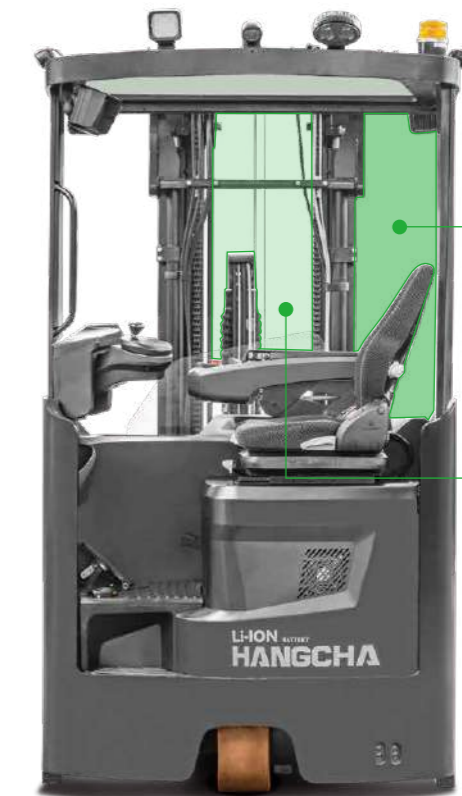

The compact mast design enables operator have a wider view around the outside of the mast.

The middle cylinder is arranged eccentrically to enable the driver to have a wider view around the inside of the mast.

EXCELLENT ERGONOMIC DESIGN

Dashboard angle adjustment

Control with a fingertip switch



Steering wheel position can also be adjusted



The pedal height can be adjusted electrically

Integral suspended seat

MULTIFUNCTIONAL INTERACTIVE COLOR-SCREEN INSTRUMENTS

The new multifunctional 4.3 inch color-screen instruments developed for the XC series reach truck have easier human-machine interfaces.



More status indication



- 1**
1. Lifting height
2. Local time
3. Load weight
- 2**
1. Driving mode
2. Fork action
3. Operating time
4. Maximum allowable lifting height
- 3**
1. Steering mode
2. Battery power
3. Travelling speed
- 4**
Various status signs and warning signs are displayed in a queue according to actual needs

More convenient shortcut button

Thanks to the integrated design of the instrument function buttons, the truck console saves a lot of physical buttons, making it more concise and efficient.



- 5**
Height selection
- 6**
Height limit
- 7**
Lighting control
- 8**
Battery removal
- 9**
Optional function switching screen
- 10**
↑ Button Driving mode switching
- 11**
↓ Button Turtle speed mode

COMPREHENSIVELY IMPROVED FUNCTION CONFIGURATION



Height selection

Multiple heights can be pre-set on the instrument. After the function is enabled, when the fork is about to be lifted to the preset height, the lifting speed will gradually slow down and the fork will finally stop at the set height steadily.

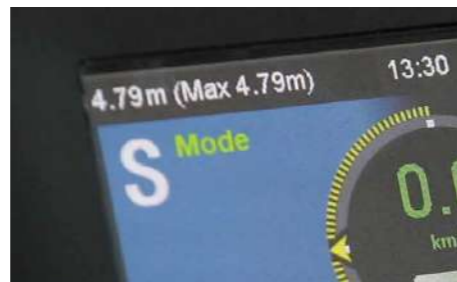

Height limit

After this function is enabled, when the fork is lifted to a certain height, this height will be set as the maximum allowable lifting height. Afterwards, whenever the fork is about to be lifted to this height, the lifting speed will gradually slow down and the fork will steadily finally stop at this height.

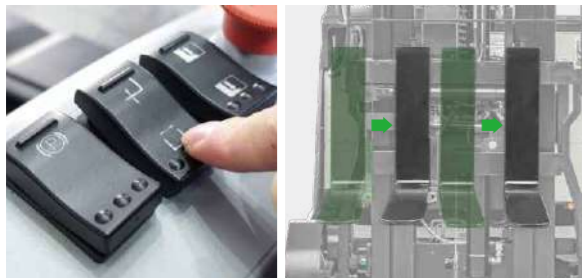

Central sideshift

Simple, reliable and fast: The central positioning of the sideshift occurs automatically, eliminating the time-consuming, cautious approach of the required position. (Only for fingertip system)

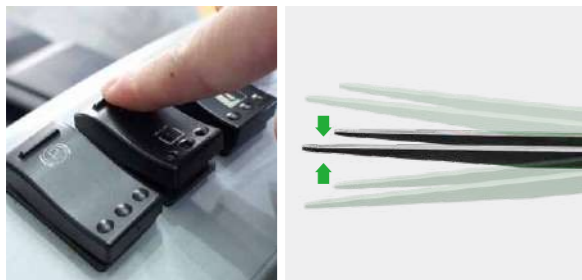

Horizontal fork

Particularly at high lift heights, the forks' tilt position is often very hard to detect. The automatic horizontal positioning significantly simplifies and accelerates pallet entry. (Only for fingertip system)



Faster, easier and safer stacking and retrieval operations





SAFETY FROM EVERY ANGLE

Drive control limit

Drive control limits the travelling speed and traverse speed as soon as the forks are raised. This increases the safety when manoeuvring with a raised pallet in front of the storage rack, while still ensuring more sensitive manoeuvring during the work cycle.

Traverse speeds (mm/s)

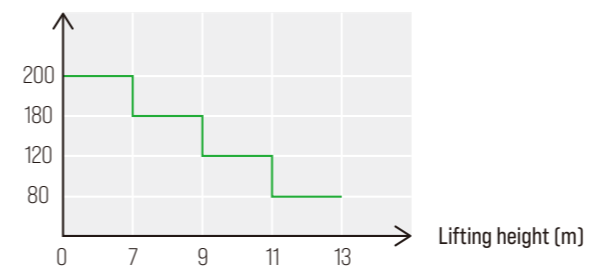

Travelling speed (km/h)

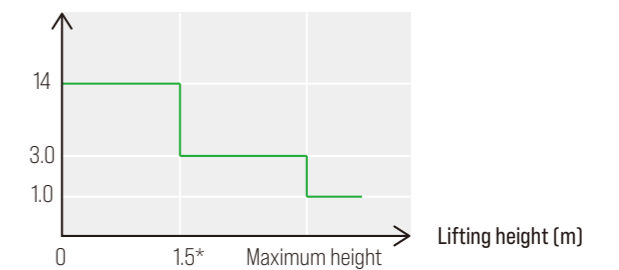

Note: The above table is only for 2.0/2.5t, the parameters of other models are not the same.

*: 1.5m is only for the fingertip system. The parameter of mechanical control system is the height of free lift.



The battery is in an inappropriate position and the indicator light is lit

Battery lock with creep speed interlock

Installed on the battery latch in the motor compartment. Monitors the locking of the battery pack. If the battery pack is not retracted or not locked, travel is restricted to creep speed.



EASY MAINTENANCE

The battery pack can be replaced quickly. The driver can unlock and remove the battery while sitting on his seat.

Remove battery pack step



The hood can be easily dismantled and mounted to facilitate routine maintenance operations.

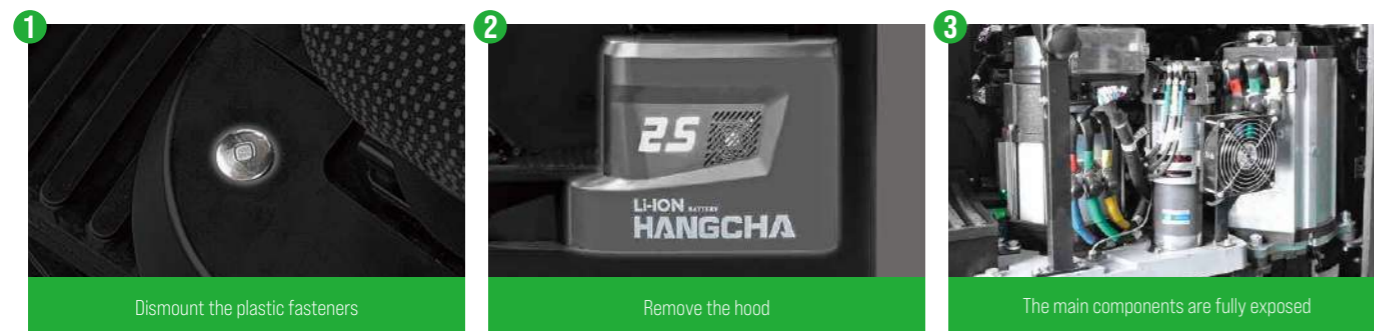

The seat can be turned open at a large angle, which is convenient for maintenance work.

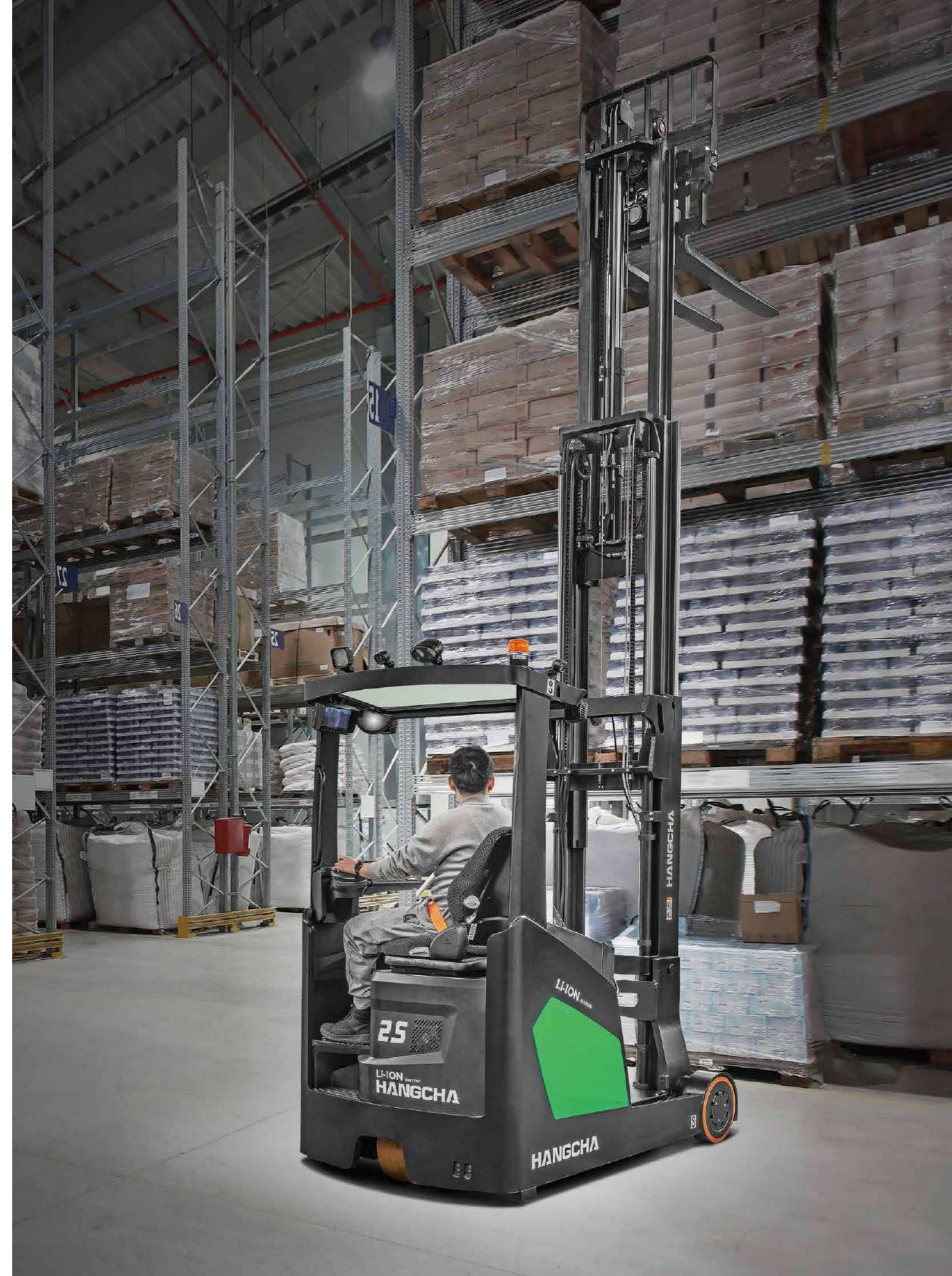
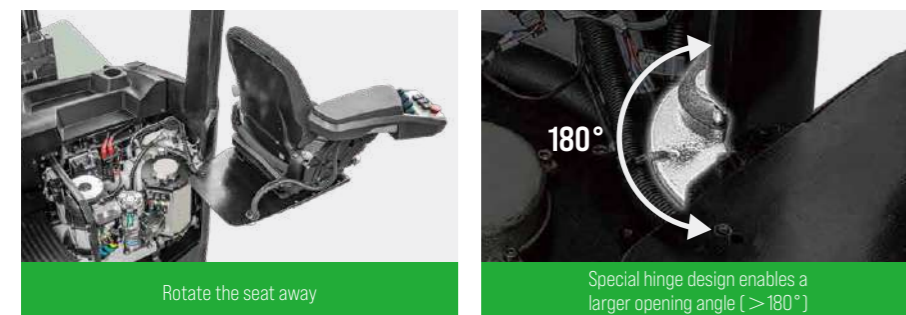



WE GIVE YOU ALL THE OPTIONS



Stacking and retrieval via video monitoring

Our video camera allows for the precise and quick access of extremely high locations. The position of the camera on the forks enables operators to efficiently and reliably control stacking and retrieval operations from their seating position/viewpoint. They no longer have to look up, which noticeably reduces the strain on their shoulders and neck. Also, information on the pallets is easily visible, even at great heights.

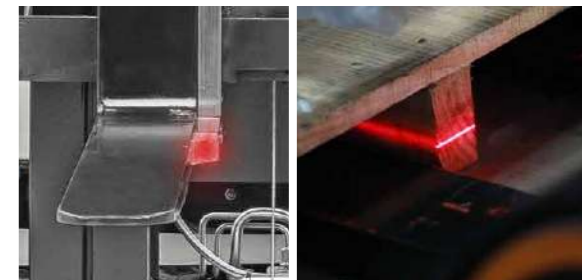

Easier stacking and retrieval with positioning laser

Our positioning lasers significantly simplify the stacking and retrieval process and increase the safety for load and rack. The laser sources are integrated into the fork tips, projecting a red line on the area ahead. This allows the operator to adjust the fork more accurately to be able to drive effortlessly into the pallet.



Easy access

Easy access protects the reach truck against unauthorised use. Authorisation management is directly controlled via the truck's display. Customised to your requirements and company size – you can choose between the key (Std.), PIN code and transponder.



Safety at any blind spots with Floor Spot

Floor Spot projects a blue dot on the floor around the truck. Especially at blind intersections or at the end of rack aisles, the Floor Spot alerts an approaching truck in time to respond.



100% clear view thanks to panorama roof panel

Maximum visibility: The panorama roof panel without cross beams provides maximum visibility of the goods and forks.



Optimum traction via traction control system

Optimum traction is ensured with braking of the drive wheel, which would otherwise spin on wet or dusty floors.

XC Series Reach Truck With Cab Is A **COLD STORAGE PRODUCT**

(meeting the -30°C cold storage environment).



/ The front, rear, top, and side windows are all made of large area tempered glass, and are equipped with front, rear, and top window wipers as standard to enhance the driver's visibility.

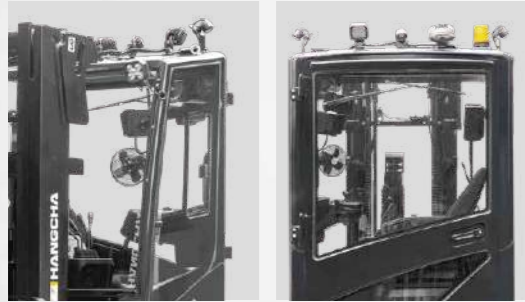

/ High power fan heater is optional to further increase the temperature in the cab (test data: the temperature in the cab can be increased to 10°C by operating in the -30°C cold storage).



Equipped with a fully enclosed cab, it has excellent performance in rust prevention, short circuit prevention, waterproofing, and insulation, meeting the usage environment of -30°C (test data: operating in a -30°C cold storage, the cab temperature is higher than 0°C)





Features

NO.	System	Features	CQD14/16/18/20/25-XC5-SI*	CQD14/16/18/20/25-XC50-SI*	CQD14/16/18/20/25-XC5-SIJS*	CQD14/16/18/20/25-XC50-SIJS*
1	Applicable environment	Cold storage model [-18 °C]	<input type="radio"/>	<input type="radio"/>	<input checked="" type="radio"/>	<input checked="" type="radio"/>
2		Cold storage model [-30 °C]	<input type="radio"/>	<input type="radio"/>	<input checked="" type="radio"/>	<input checked="" type="radio"/>
3		Full closed cab	/	/	<input checked="" type="radio"/>	<input checked="" type="radio"/>
4	Control	Control with a mechanical control lever	<input checked="" type="radio"/>	/	<input checked="" type="radio"/>	/
5		Control with a fingertip switch	/	<input checked="" type="radio"/>	/	<input checked="" type="radio"/>
6		Height display	<input type="radio"/> (Only for triplex mast, excluding the free lift range)	<input checked="" type="radio"/> (Including the free lift range)	<input type="radio"/> (Only for triplex mast, excluding the free lift range)	<input checked="" type="radio"/> (Including the free lift range)
7		Height selection	<input type="radio"/> (Only for triplex mast, excluding the free lift range)	<input checked="" type="radio"/> (Including the free lift range)	<input type="radio"/> (Only for triplex mast, excluding the free lift range)	<input checked="" type="radio"/> (Including the free lift range)
8		Height limit	<input type="radio"/> (Only for triplex mast, excluding the free lift range)	<input checked="" type="radio"/> (Including the free lift range)	<input type="radio"/> (Only for triplex mast, excluding the free lift range)	<input checked="" type="radio"/> (Including the free lift range)
9		Central sideshift	/	<input type="radio"/>	/	<input type="radio"/>
10		Horizontal fork alignment	/	<input type="radio"/>	/	<input type="radio"/>
11		Mast reach damping system	<input checked="" type="radio"/>	<input checked="" type="radio"/>	<input checked="" type="radio"/>	<input checked="" type="radio"/>
12		Electric lowering limit - Stop forks above outriggers if mast is retracted	<input type="radio"/>	<input checked="" type="radio"/>	<input type="radio"/>	<input type="radio"/>
13		Soft landing system	/	<input type="radio"/>	/	<input type="radio"/>
14		Lifting damping system	<input checked="" type="radio"/>	<input checked="" type="radio"/>	<input checked="" type="radio"/>	<input checked="" type="radio"/>
15		Drive control limit	<input checked="" type="radio"/>	<input checked="" type="radio"/>	<input checked="" type="radio"/>	<input checked="" type="radio"/>
16	Drive wheel skid control system	<input type="radio"/>	<input type="radio"/>	<input type="radio"/>	<input type="radio"/>	
17	Battery lock with creep speed interlock	<input checked="" type="radio"/>	<input checked="" type="radio"/>	<input checked="" type="radio"/>	<input checked="" type="radio"/>	
18	Travelling speed control at corner	<input checked="" type="radio"/>	<input checked="" type="radio"/>	<input checked="" type="radio"/>	<input checked="" type="radio"/>	
19	180° steering mode	<input checked="" type="radio"/>	<input checked="" type="radio"/>	<input checked="" type="radio"/>	<input checked="" type="radio"/>	
20	360° steering mode	<input type="radio"/>	<input type="radio"/>	<input type="radio"/>	<input type="radio"/>	
21	Transmission system	ZF transmission	<input checked="" type="radio"/>	<input checked="" type="radio"/>	<input checked="" type="radio"/>	<input checked="" type="radio"/>
22	Electronic accessories	USB power socket	<input checked="" type="radio"/>	<input checked="" type="radio"/>	<input checked="" type="radio"/>	<input checked="" type="radio"/>
23		Fork video monitoring and positioning laser	<input type="radio"/>	<input type="radio"/>	<input type="radio"/>	<input type="radio"/>
24		Keyed start	<input checked="" type="radio"/>	<input checked="" type="radio"/>	<input checked="" type="radio"/>	<input checked="" type="radio"/>
25		Start with a PIN code or by a card	<input type="radio"/>	<input type="radio"/>	<input type="radio"/>	<input type="radio"/>
26		Beep	<input type="radio"/>	<input type="radio"/>	<input type="radio"/>	<input type="radio"/>
27		Operating light (in the direction of the fork)	<input checked="" type="radio"/>	<input checked="" type="radio"/>	<input checked="" type="radio"/>	<input checked="" type="radio"/>
28		Operating light (in the reverse direction of the fork)	<input type="radio"/>	<input type="radio"/>	<input type="radio"/>	<input type="radio"/>
29		Alarm light	<input checked="" type="radio"/>	<input checked="" type="radio"/>	<input checked="" type="radio"/>	<input checked="" type="radio"/>
30		Blue light	<input type="radio"/>	<input type="radio"/>	<input type="radio"/>	<input type="radio"/>
31		Three-sided one line laser projection light	<input type="radio"/>	<input type="radio"/>	<input type="radio"/>	<input type="radio"/>
32		Reading light in the car	/	/	<input checked="" type="radio"/>	<input checked="" type="radio"/>
33		Double -speed wind speed heater	/	/	<input type="radio"/>	<input type="radio"/>
34		Electric fan	<input type="radio"/>	<input type="radio"/>	<input type="radio"/>	<input type="radio"/>
35		The front window glass double -speed wiper	/	/	<input checked="" type="radio"/>	<input checked="" type="radio"/>
36	Back window glass double -speed wiper	/	/	<input checked="" type="radio"/>	<input checked="" type="radio"/>	
37	Top window glass double -speed wiper	/	/	<input checked="" type="radio"/>	<input checked="" type="radio"/>	
38	Front window glass spray water	/	/	<input checked="" type="radio"/>	<input checked="" type="radio"/>	
39	Ergonomic design	Electrical adjustment of pedal height	<input type="radio"/>	<input type="radio"/>	<input type="radio"/>	<input type="radio"/>
40		Adjustable steering wheel	<input checked="" type="radio"/>	<input checked="" type="radio"/>	<input checked="" type="radio"/>	<input checked="" type="radio"/>
41	Instrument angle adjustment	<input checked="" type="radio"/>	<input checked="" type="radio"/>	<input checked="" type="radio"/>	<input checked="" type="radio"/>	
42	Fault Diagnosis	Suctioned oil filter clogging alarm	<input type="radio"/>	<input type="radio"/>	<input type="radio"/>	<input type="radio"/>
43		Backflow oil filter clogging alarm	<input type="radio"/>	<input checked="" type="radio"/>	<input type="radio"/>	<input checked="" type="radio"/>
44	Seat	Sequential Seat Belt Interlock System	<input checked="" type="radio"/>	<input checked="" type="radio"/>	<input checked="" type="radio"/>	<input checked="" type="radio"/>
45		BF6-3 suspension seat	<input checked="" type="radio"/>	/	<input checked="" type="radio"/>	/
46	MS665/522 suspension seat	<input type="radio"/>	<input checked="" type="radio"/>	/	<input checked="" type="radio"/>	
47	Other	Panorama roof	<input type="radio"/>	<input type="radio"/>	<input checked="" type="radio"/>	<input checked="" type="radio"/>
48		PVC ceiling	<input type="radio"/>	<input type="radio"/>	/	/
49		The side glass can be opened	/	/	<input checked="" type="radio"/>	<input checked="" type="radio"/>
50		Broken window	/	/	<input checked="" type="radio"/>	<input checked="" type="radio"/>
51		Moving the side of the battery	<input type="radio"/>	<input type="radio"/>	<input type="radio"/>	<input type="radio"/>
52		Curved rearview mirror	<input type="radio"/>	<input type="radio"/>	<input type="radio"/>	<input type="radio"/>
53		Left and right rear view mirrors	<input type="radio"/>	<input type="radio"/>	/	/
54		Load backrest	<input checked="" type="radio"/>	<input checked="" type="radio"/>	<input checked="" type="radio"/>	<input checked="" type="radio"/>
55		Fire extinguisher	<input type="radio"/>	<input type="radio"/>	<input type="radio"/>	<input type="radio"/>
56		OPS system	<input checked="" type="radio"/>	<input checked="" type="radio"/>	<input checked="" type="radio"/>	<input checked="" type="radio"/>

Note: ● Standard; ○ Optional
★ CE model

XC Series Reach Truck With Lithium Power Specification

Distinguishing mark	1.1	Manufacturer	HANGCHA GROUP CO.,LTD.					
	1.2	Model		CQD14-XC5-SI* CQD14-XC5D-SI*	CQD16-XC5-SI* CQD16-XC5D-SI*	CQD18-XC5-SI* CQD18-XC5D-SI*	CQD20-XC5-SI* CQD20-XC5D-SI*	CQD25-XC5-SI* CQD25-XC5D-SI*
1.3	Power unit		Li-Ion battery	Li-Ion battery	Li-Ion battery	Li-Ion battery	Li-Ion battery	
1.4	Manual		Seated	Seated	Seated	Seated	Seated	
1.5	Rated capacity/rated load	Q(t)	1.4	1.6	1.8	2	2.5	
1.6	Load centre distance	c(mm)	600	600	600	600	600	
1.8	Load distance	x(mm)	360 ¹⁷⁾	410 ¹⁷⁾	385 ¹⁸⁾	362 ²⁰⁾	484 ²⁰⁾	
1.8.1	Load distance, mast reached forward	x1(mm)	211 ²⁾	211 ²⁾	203	232	232	
1.9	Wheelbase	y(mm)	1355	1405	1405	1471	1601	
Weight	2.1	Net weight incl. battery (see row 6.5)	(kg)	3330	3370	3370	3470	3620
Tyres, chassis	3.1	Tyres		PU	PU	PU	PU	PU
	3.2	Tyre size, front		φ343×140	φ343×140	φ343×140	φ343×140	φ400×160
	3.3	Tyre size, rear		φ285×100	φ285×100	φ285×100	φ343×108	φ343×108
	3.5	Wheels, number front/rear (x = driven wheels)		1x/2	1x/2	1x/2	1x/2	1x/2
	3.7	Tread width, rear	b11(mm)	1174	1174	1174	1162	1162
Dimensions	4.1	Tilt of fork carriage forward/backward	α/β(°)	2.0/5.0	2.0/5.0	2.0/5.0	2.0/5.0	2.0/5.0
	4.2	Height, mast lowered	h1(mm)	2100	2100	2100	2100	2100
	4.3	Free lift	h2(mm)	105	105	110	110	110
	4.4	Lift	h3(mm)	3000	3000	3000	3000	3000
	4.5	Height, mast extended	h4(mm)	3965	3965	3965	3965	3965
	4.7	Height of overhead guard	h6(mm)	2263	2263	2263	2263	2263
	4.8	Seat height	h7(mm)	1159	1159	1159	1159	1159
	4.10	Height of support arms	h8(mm)	308	308	308	365.5	365.5
	4.19	Overall length	h(mm)	2400 ³⁾	2400 ³⁾	2425 ⁷⁾	2514 ²¹⁾	2542 ²¹⁾
	4.20	Length to face of forks	l2(mm)	1250 ³⁾	1250 ³⁾	1275 ⁷⁾	1364 ²¹⁾	1392 ²¹⁾
	4.21	Overall width	b1/b2(mm)	1270/1270	1270/1270	1270/1270	1270/1270	1270/1270
	4.22	Fork dimensions	s/e/l(mm)	35×120×1150	35×120×1150	40×122×1150	40×122×1150	40×122×1150
	4.23	Fork carriage ISO 2328, class/type A, B		II A	II A	II A	II A	II A
	4.24	Fork-carriage width	b3(mm)	830	830	830	830	830
	4.25	Distance between fork-arms	b5(mm)	750	750	750	750	750
	4.26	Distance between wheel arms	b4(mm)	940	940	940	940	940
	4.28	Reach distance	l4(mm)	571 ⁴⁾	621 ¹³⁾	588 ¹⁸⁾	594 ²⁰⁾	716 ²⁰⁾
	4.32	Ground clearance, centre of wheelbase	m2(mm)	80	80	80	80	80
	4.33	Aisle width for pallets 1000 × 1200 sideways	Ast1(mm)	2687 ⁵⁾	2701 ⁵⁾	2719 ⁹⁾	2802 ²²⁾	2867 ²⁴⁾
	4.34	Aisle width for pallets 800 × 1200 lengthways	Ast2(mm)	2740 ⁶⁾	2745 ⁶⁾	2768 ¹⁰⁾	2855 ²³⁾	2896 ²⁵⁾
4.35	Turning radius	Wa(mm)	1610	1660	1660	1726	1876	
4.37	Length over the support arms	l1(mm)	1775	1825	1825	1920	2070	
Performance data	5.1	Travel speed, laden/unladen	(km/h)	14/14	14/14	14/14	14/14	14/14
	5.2	Lift speed, laden/unladen	(m/s)	0.61/0.81	0.59/0.81	0.5/0.7	0.48/0.7	0.45/0.7
	5.3	Lowering speed, laden/unladen	(m/s)	XC4:0.52/0.52 XC4D:0.56/0.56	XC4:0.52/0.52 XC4D:0.56/0.56	XC4:0.52/0.52 XC4D:0.56/0.56	XC4:0.52/0.52 XC4D:0.56/0.56	XC4:0.52/0.52 XC4D:0.56/0.56
	5.4	Traverse speed w. / w.o. load	(m/s)	0.24/0.24	0.24/0.24	0.2/0.2	0.2/0.2	0.2/0.2
	5.8	Max. gradeability, laden/unladen 5min	(%)	10.0/15.0	10.0/15.0	10.0/15.0	10.0/15.0	10.0/15.0
	5.10	Service brake		Electromagnetic	Electromagnetic+Mech.	Electromagnetic+Mech.	Electromagnetic+Mech.	Electromagnetic+Mech.
Electric-engine	6.1	Drive motor rating S2 60 min.	(kW)	8.1	8.1	8.1	8.1	8.1
	6.2	Lift motor rating at S3 15%	(kW)	20	20	20	20	20
	6.3	Battery as per DIN 43531 /35/36 A, B, C, no		no	no	no	no	no
	6.4	Battery voltage, nominal capacity	(V/Ah)	80/250	80/250	80/250	80/250	80/250
	6.4.1	Battery voltage, rated capacity, Optional	(V/Ah)	80/404	80/404	80/404	80/404	80/404
6.5	Battery weight (+5%)	(kg)	275	275	275	360	360	
Additional data	10.1	Operating pressure for attachments	(bar)	150	150	150	150	150
	10.2	Oil flow for attachments	(l/min)	18	18	18	18	18
	10.7	Sound pressure level LpAZ (at the driver's seat)	(db(A))	68	68	68	68	68

Note: 1) h3>7000mm:-25mm. 2) h3>7000mm:-8mm. 3) h3>7000mm:+25mm. 4) h3>7000mm:-33mm. 5) h3>7000mm:+19mm. 6) h3>7000mm:+23mm. 7) With optional battery 80V/404Ah, h3>7000mm:-90mm.
 8) With optional battery 80V/404Ah, h3>7000mm: +90mm. 9) With optional battery 80V/404Ah, h3>7000mm: +68mm. 10) With optional battery 80V/404Ah, h3>7000mm: +82mm. 11) With optional battery 80V/404Ah, h3>7000mm: -115mm.
 12) With optional battery 80V/404Ah, h3>7000mm: +115mm. 13) With optional battery 80V/404Ah, h3>7000mm: -123mm. 14) With optional battery 80V/404Ah, h3>7000mm: +87mm. 15) With optional battery 80V/404Ah, h3>7000mm: +105mm.
 16) With optional battery 80V/404Ah: -90mm. 17) With optional battery 80V/404Ah: +90mm. 18) With optional battery 80V/404Ah: +67mm. 19) With optional battery 80V/404Ah: +81m. 20) h3>12000mm:-150mm. 21) h3>12000mm:+150mm.
 22) h3>12000mm:+115mm. 23) h3>12000mm:+137mm. 24) h3>12000mm:+105mm. 25) h3>12000mm:+134mm.
 ★ CE model

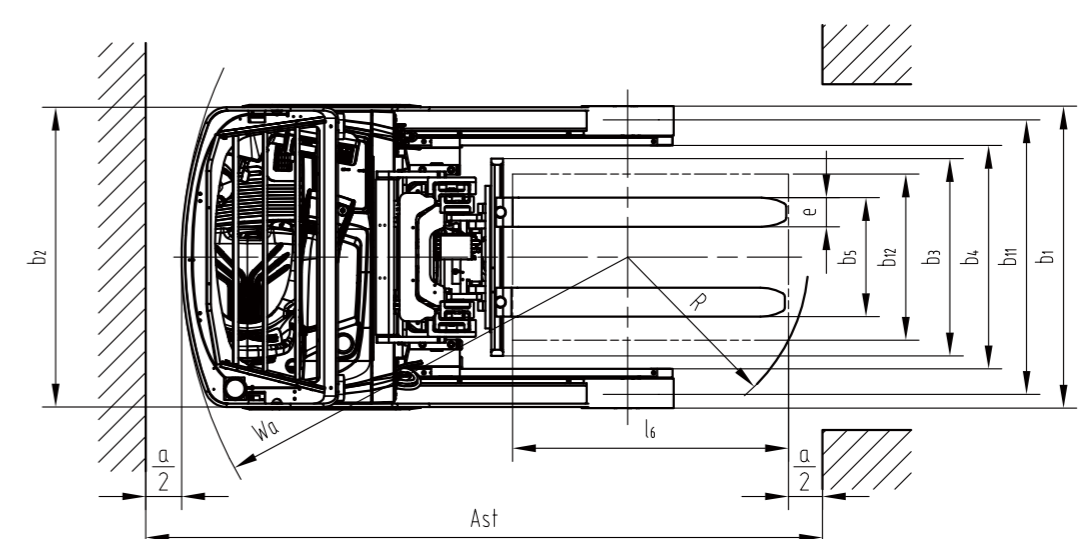
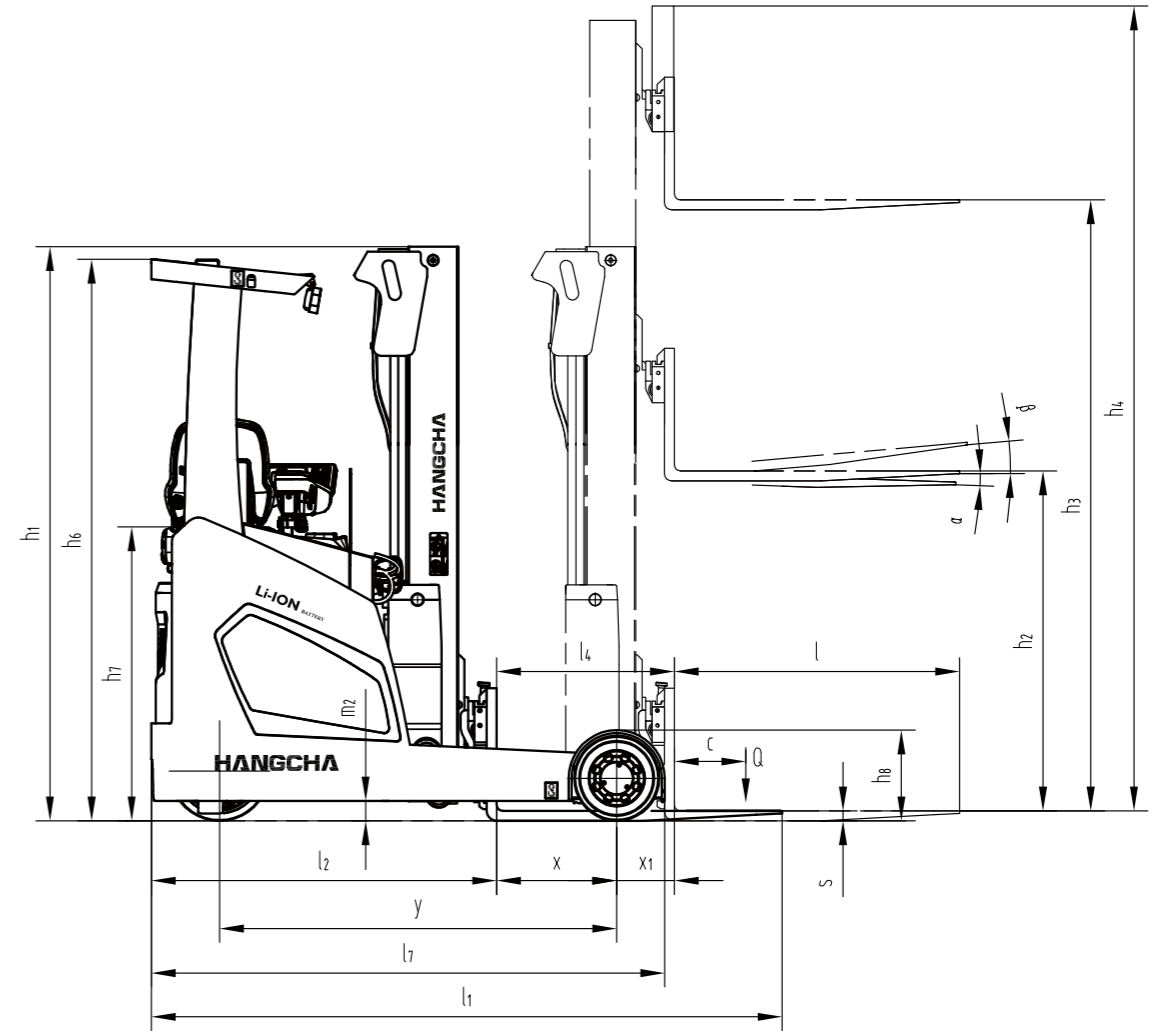

$$A_{st} = W_a + R + a = W_a + \sqrt{(l_6 - x)^2 + \left(\frac{b_{12}}{2}\right)^2} + a$$

