

# Lonking 龙工

## CDM6025 HYDRAULIC EXCAVATOR

Efficiency Rules the Future

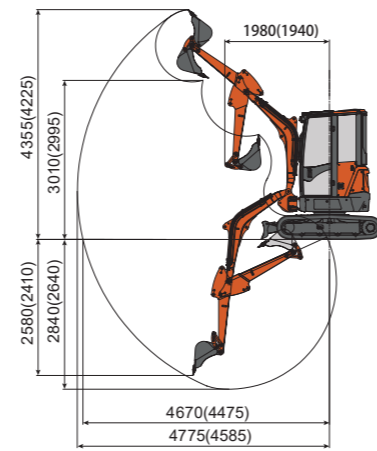
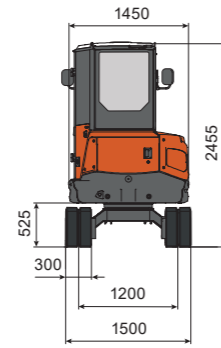
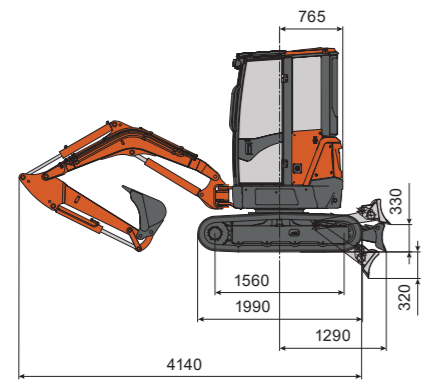

### TECHNICAL PARAMETERS

Name		Data
Basic	Operating weight	2650 kg
	Standard bucket Capacity	0.08 m <sup>3</sup>
	Standard bucket Width	580 mm
	Max.Travel speed	2.6/4.4km/h
	Max.Swing speed	10 rpm
	Grade ability	30°
	Ground pressure	25.1 kPa
	Max.Traction force	30.7 KN
Engine	Boom swing angle (L/R)	65°/50°
	Engine brand	YANMAR
	Engine model	3TNV80F-SPSU
	Rated power	14.6 kW/2400 rpm
	Displacement	1.267 L
Hydraulic	Fuel tank	26 L
	Max.Flow(total)	2×28.8+19.2+6.5 L/min
	Max.Working pressure	23.5 MPa
	Max.Pilot pressure	3.2 Mpa
	Max.Arm digging force	14(15.8) kN
	Max.Bucket digging force	24 kN
Chassis	Hrdraulic oil tank	41 L
	Track width	300 mm
	Track type	Rubber crawler
	Carrier rollers number	1( each side)
Electric	Track rollers number	4( each side)
	System vottage	12 V
	Battery capacity	12 V,45 Ah

### STANDARD EQUIPMENT

Fops/Tops cabin
Suspension seat
Warm air blower
Hydraulic pilot control rod
Deflectable boom
Warning light
Breaker pipeline

### OPTIONAL EQUIPMENT

Electro-hydraulic proportional joystick
Front safeguard
Fops/Tops canopy
300mm width bucket
1000mm width bucket
Quick hitch pipeline
300mm steel tracks

### PRODUCT FEATURES

Yanmar Strong Power Engine.Emission level reaches USA T4F and EU Stage V .
The combination of zero-tail swing and boom deviation is designed for narrow and complicated working scenarios.
Wider space and view are provide by enlarged front windscreen and sunroof.
Color monitoring digital and analogue combined display
The door and hood can be opened completely to ensure easy and convenient maintenance.
Retractable chassis , good trafficability and more stable.

The following blank can be used for notes or comments.

For more information on Lonking products,  
Please contact our local agent:

Lonking (FU JIAN) INTERNATIONAL TRADE CO., LTD.

**Lonking Holdings Limited**

Add:26 Minyi Road,Xinqiao,Songjiang Industrial Zone,Shanghai

Tel: +86-21-3760 2242 E-mail:export@lonking.cn

<http://www.lonkinggroup.com>

OPERATING WEIGHT:	2650kg
ENGINE POWER:	14.6kW
BUCKET CAPACITY:	0.08m <sup>3</sup>
TRAVEL SPEED:	2.6/4.4km/h